



MUDFLAPS • ACCESSORIES

**USA Manufactured Rubber & Poly
Mudflaps
Customizable with your company logo**



G-Force Aerodynamic Mud Flaps

The Ultimate Aerodynamic Mud Flap Reduces Fuel Costs!

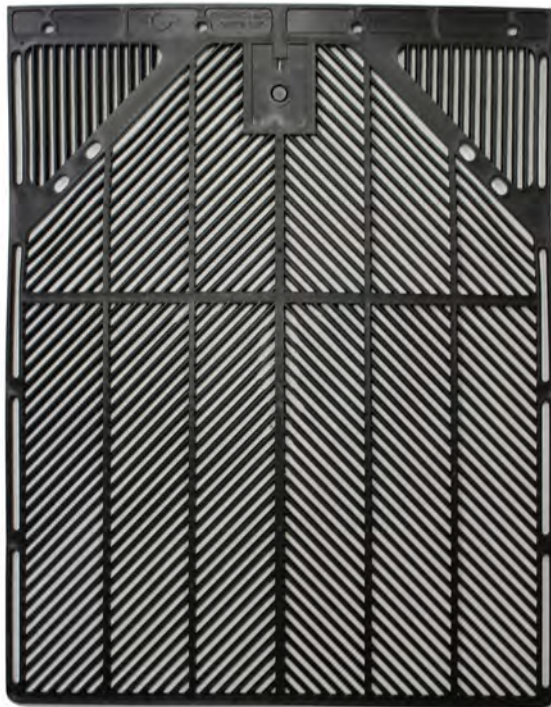

Part Number	Description	Weight Per Pair
GT-2424GFB	24x24 G-Force Aerodynamic Flap	10 lbs.
GT-2430GFB	24x30 G-Force Aerodynamic Flap	12 lbs.

- Reduces Fuel Costs
- Reduces Spray
- Anti-Sail
- Cold Temps to -42 degrees
- Optional LED light

Endorsed by Wright-Patterson Air Force Base

"Symmetric wing shaped airfoil design for each rib provides lowest drag coefficient optimizing air flow and improving fuel efficiency. Aerodynamic design allows air to through reducing movement of mud flaps at higher speeds maintaining their protective function. Vertical and angled ribs help to dissipate moisture and debris in a safe manner at all weather conditions and speeds. The G-Force 400 is weighted at an optimal 4.5 pounds and will not flex, bend or rotate at higher speeds. As an engineer I endorse this product due to its aerodynamic angled rib foil design allowing air to pass through yet keeping its protective function giving customers a fuel efficient durable mud flap."

-John G. Czikk, C-130 Avionics Modernization Program
Engineer
Wright Patterson Air Force Base
Dayton, Ohio

Watch the Video on  YouTube
or Visit our Website



3/16" Economy DIAMOND Rubber AV Mud Flaps

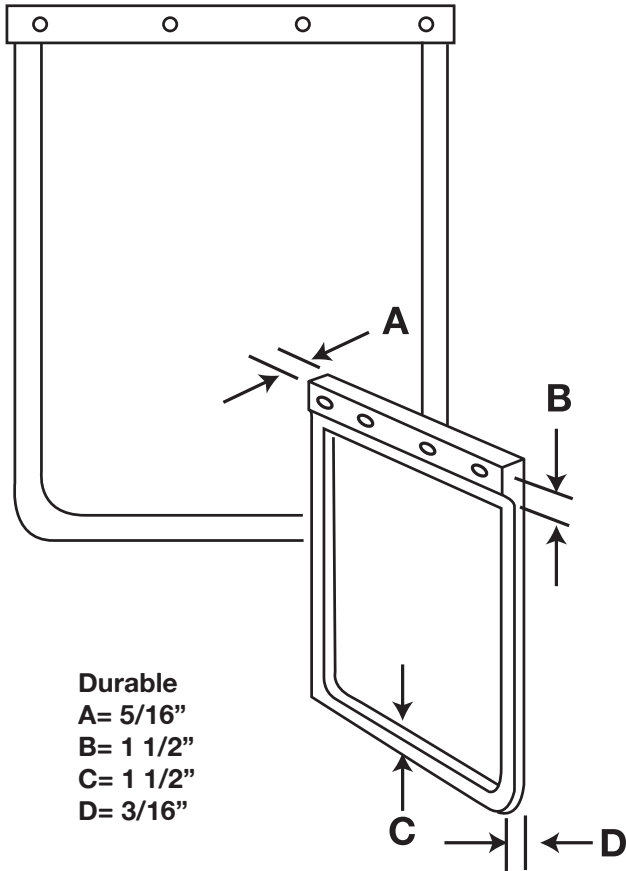

Globetech's Diamond Mud Flaps

Globetech uses the finest material available to mold its Diamond mud flaps. These are very popular mud flaps for everyday use including off road and over the road applications.



Part Number	Description	Weight Per Pair
GT-2424D	24x24 Diamond Economy Mud flap	8 lbs.
GT-2430D	24x30 Diamond Economy Mud flap	12 lbs.
GT-2436D	24x36 Diamond Economy Mud flap	14 lbs.



ARMOR GUARD COMPOUND

Unvulcanized Friction Compound



Globetech Compound 6807

Typical Properties:

Density:	1.16± .04 gms/cm
Shore A Durometer:	70 Duro ± 8
Tensile Strength:	2000 Minimum
Elongation	300% Minimum

Globetech Material Reinforced Ultimate Tear Strength!

Basic Material is commercial productive tire tread compound or similar. Reinforced with polyester and nylon fiber. SBR/NR

ASTM D624 - 00(2012)

Standard test method for tear strength of conventional vulcanized rubber and thermoplastic elastomers

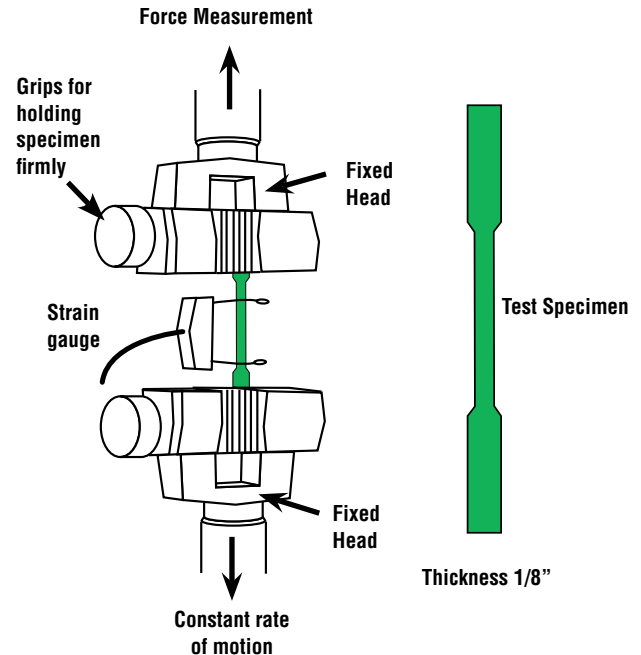
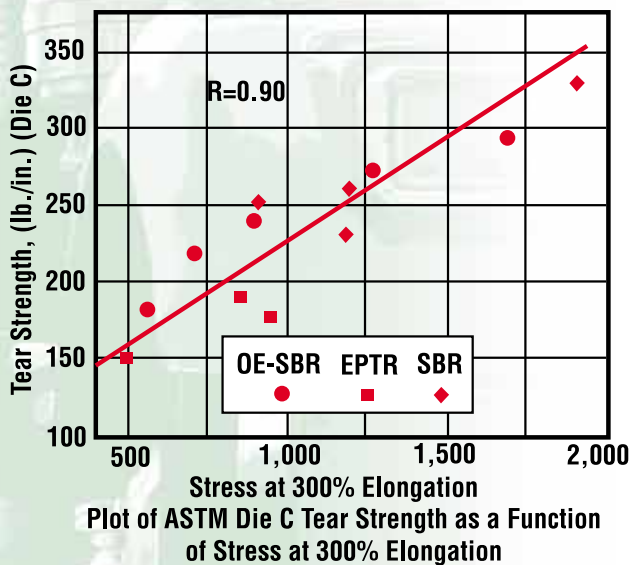



ARMOR GUARD Rubber Mud Flaps

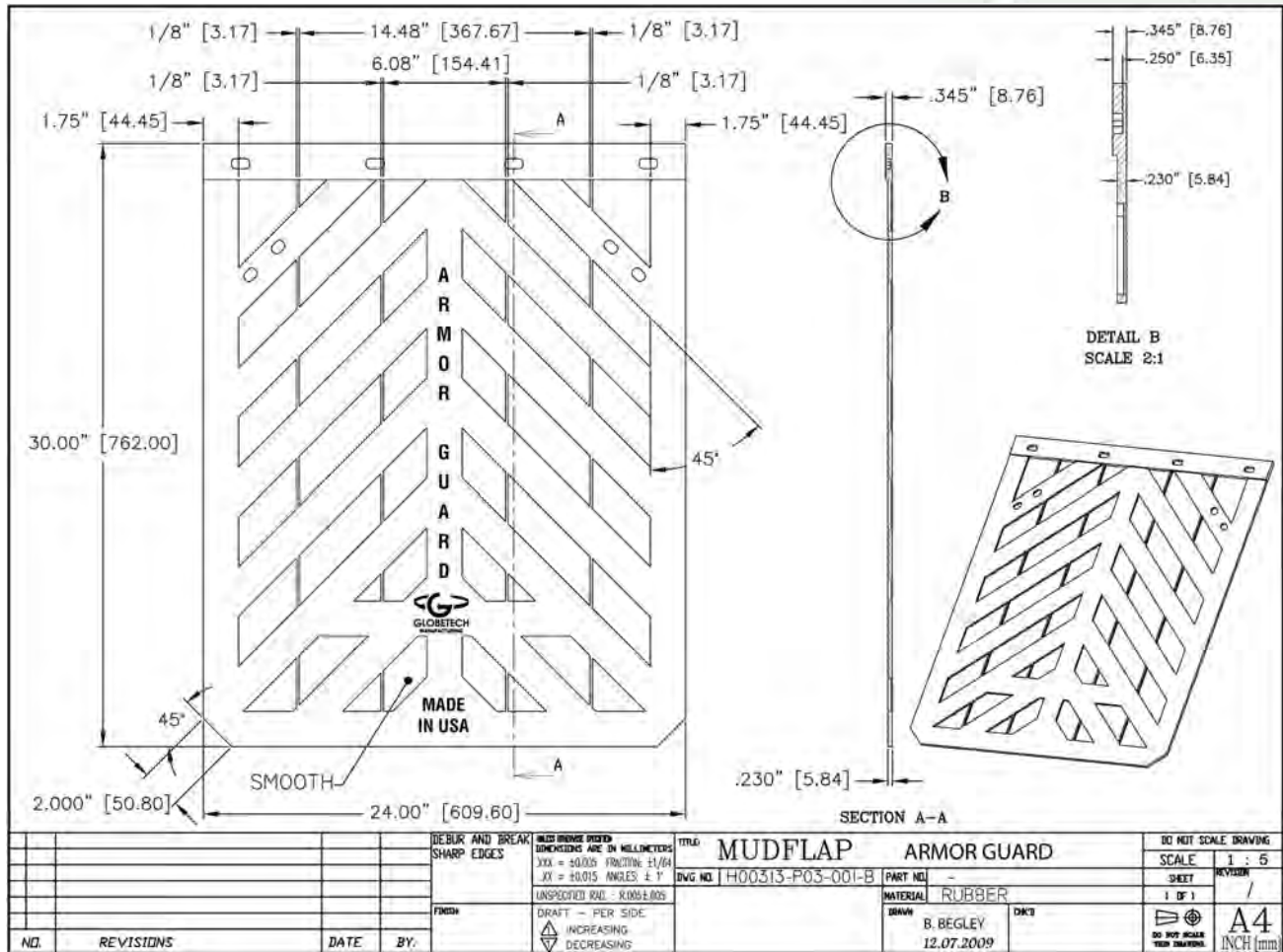

Rubber Mud Flaps



ARMOR GUARD MUD FLAP

The Armor Guard splash guard is made from 100% fiber reinforced rubber. The header is molded thicker to resist tearing through normal use. The top corners can be cut to fit standard 45 degree angle brackets. While the bottom can be cut down when a shorter flap is needed.

**100% High Tear Strength
Best Flap On The Market!**

Part Number	Description	Weight Per Pair	Replaces No.
GT-2424CD	24x24 Armor Guard Domestic	12 lbs.	062424
GT-2430CD	24x30 Armor Guard Domestic	14 lbs.	062430
GT-2436CD	24x36 Armor Guard Domestic	16 lbs.	062436



5/16" Standard Rubber Mud Flaps

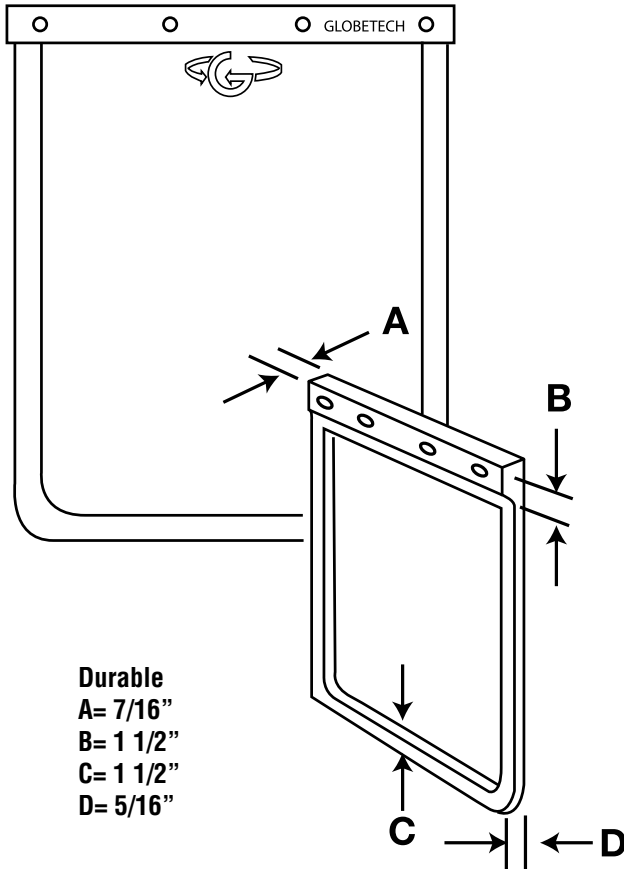

Globetech's Standard Mud Flaps

Globetech uses the finest material available to mold its standard mud flaps. These are the most popular mudflaps for logo use.

This material also meets all MIL-SPEC for Military Contractors.



Our 5/16" Standard splash guards are slightly heavier than our Chevron flaps. The majority of our customers prefer the Standard flap for their Custom logos.



Part Number	Description	Weight Per Pair
GT-1218S	12x18 Standard Rubber Mud Flap	4 lbs.
GT-1924S	19x24 Standard Rubber Mud Flap	5 lbs.
GT-2015S	20x15 Standard Rubber Mud Flap	7 lbs.
GT-2414S	24x14 Standard Rubber Mud Flap	11 lbs.
GT-2418S	24x18 Standard Rubber Mud Flap	11 lbs.
GT-2424S	24x24 Standard Rubber Mud Flap	13lbs.
GT-2430S	24x30 Standard Rubber Mud Flap	15lbs.
GT-2436S	24x36 Standard Rubber Mud Flap	17lbs.



3/8" XTREME Rubber Mud Flaps



Nylon Mesh Reinforcement

Part Number	Description	Weight Per Pair
GT-2424XD	24x24 3/8" XTREME Mud Flap	16 lbs.
GT-2430XD	24x30 3/8" XTREME Mud Flap	17 lbs.
GT-2436XD	24x36 3/8" XTREME Mud Flap	19 lbs.
GT-2440XD	24x40 3/8" XTREME Mud Flap	21lbs.
GT-2442XD	24x42 3/8" XTREME Mud Flap	24lbs.



XTREME



Correlation of Constrained Path Tear versus Off Road Tire Performance

The chart below illustrates the degree of correlation between CP tear strength at 100°C and the cutting-chipping rating of a series of compounds in an off-road tire performance test.

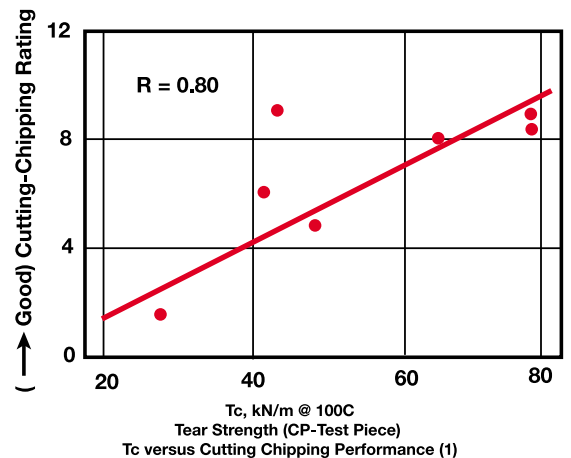

XTREME MUD FLAP

- Our Xtreme Mud Flap is molded from high tensile strength rubber. Using conveyor belt technology, a wire of nylon sheet is molded into the mud flap for greater durability.
- Great for dump trucks and off-road use
- Highest tear strength of any mud flap
- Stiffer flap prevents waving
- Available with silk-screen or raised molded logo

ABSOLUTE TOUGHEST FLAP ON THE MARKET!
REPLACES: STA-PUT-FLAPS



1/2" HEAVY DUTY Anti-Spray Mud Flaps



The **Heavy-Duty, Anti-Spray Flap** is the ultimate flap. The 1/2" thick reinforced rubber gives the flap anti-sail features. Raised knobs on the back side for anti-spray.

Part Number	Description	Weight Per Pair	Replaces Koneta
GT-2424HDD	24x24 1/2" Heavy Duty USA Mud Flap	19 lbs.	082424
GT-2430HDD	24x30 1/2" Heavy Duty USA Mud Flap	22 lbs.	082430
GT-2436HDD	24x36 1/2" Heavy Duty USA Mud Flap	24 lbs.	082436

- 45 Degree angle mount capable
- 30/36 dual mount capable
- Hole at bottom of flap for hook up
- Available with silk-screen or raised molded logo



Quick Change, AS Anti-Spray Mud Flaps



Part Number	Description	Weight Per Pair	Replaces Koneta
GT-2424AS	24x24 Quick Change Anti-Spray Mud Flap	18 lbs.	84500
GT-2430AS	24x30 Quick Change Anti-Spray Mud Flap	24 lbs.	84502
GT-2436AS	24x36 Quick Change Anti-Spray Mud Flap	30 lbs.	84504

ALL-RUBBER ANTI SPRAY QUICK CHANGE MUD FLAPS

Save time and money with two-step Quick Change Mud Flaps!

The Quick Change Anti-Spray mud flap features the easy two-step quick changeability plus finger-like projections directing spray downward while the built-in side ridges prevent lateral spray.

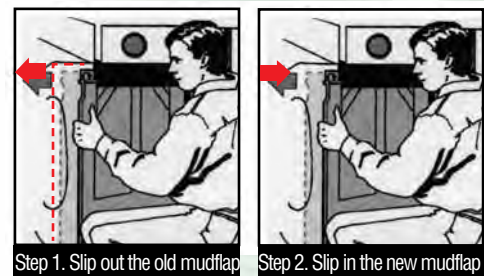



Anti-Sail Quick Mount Mud Flaps



Two embedded, all-steel bars resist wind force, even at high speeds. The convenience of quick maintenance combined with the stability of steel reinforcement bars.

Part Number	Description	Weight Per Pair	Replaces Koneta
GT-2430M	24x30 3/8" Quick Mount Mud Flap	20 lbs.	82506
GT-2436M	24x36 3/8" Quick Mount Mud Flap	22 lbs.	82504



Raintrapper Rubber Mud Flaps



The Raintrapper flap is manufactured in the U.S.A. by Globetech Manufacturing. This is the ultimate anti-spray mud flap for the heavy duty trucking industry. The Raintrapper mud flap features the finger-like projections directing spray downward while the built-in side ridges prevent lateral spray.

Part Number	Description	Weight Per Pair	Replaces Koneta No.
GT-2430RT	24x30 Raintrapper Flap	20 lbs.	84502

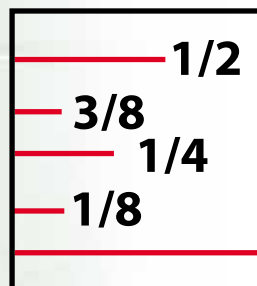
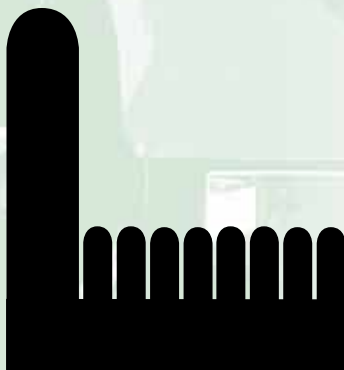

← Profile diagram showing finger-like projections



A MUST HAVE FOR DUMP TRUCKS!

MidGuard Mud Flaps

MidGuard Mud Flaps provide unsurpassed protection from flying gravel, splash and road spray. Available in three thicknesses.

Part Number	Description	Replaces
GT-443638	3/8" x 44" x 36"	140002
GT-4224XD	3/8" x 42" x 24"	n/a

Side Shields

- Side Shields offer ribbed construction to reduce spray from sides of trailers.



Part Number	Description	Replaces
GT-848S	Side Skirt Fap, 8" x 48" Rubber	074807





3/16" Polyguard Standard

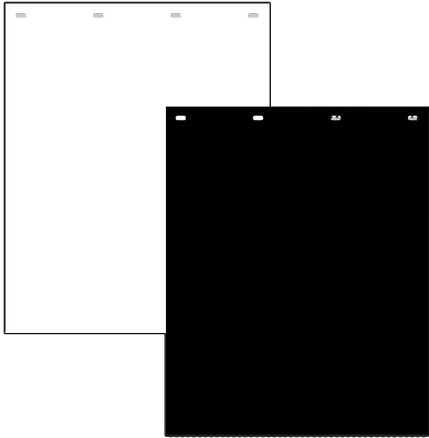

Part Number	Description	Weight Per Pair
2424PSB	24X24 Standard Poly - Black	
2424PSW	24X24 Standard Poly - White	6 lbs.
2430PSB	24x30 Standard Poly - Black	
2430PSW	24x30 Standard Poly - White	8 lbs.
2436PSB	24x36 Standard Poly - Black	
2436PSW	24x36 Standard Poly - White	10lbs.

Poly Standard Profile - Smooth Back

- 3/16" Thick
- Will not crack or curl
- Economic Price

1/4" Anti-Spray Poly Plus

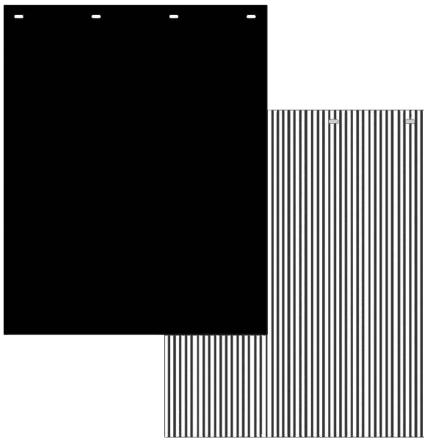

Part Number	Description	Weight Per Pair
2424PPSB	24X24 1/4" Anti-Spray - Black	
2424PPSW	24X24 1/4" Anti-Spray - White	7 lbs.
2430PPSB	24x30 1/4" Anti-Spray - Black	
2430PPSW	24x30 1/4" Anti-Spray - White	9 lbs.
2436PPSB	24x36 1/4" Anti-Spray - Black	
2436PPSW	24x36 1/4" Anti-Spray - White	11lbs.

Poly Plus Profile - Anti-Spray Back

- 1/4" Thick
- Anti-Spray Ribbed Back
- Medium Duty

3/8" Anti-Spray Poly Plus HD

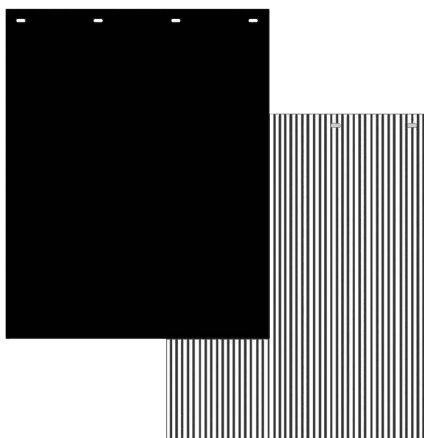

Part Number	Description	Weight Per Pair
2424PHDB	24X24 3/8" Anti-Spray - Black	
2424PHDW	24X24 3/8" Anti-Spray - White	10 lbs.
2430PHDB	24x30 3/8" Anti-Spray - Black	
2430PHDW	24x30 3/8" Anti-Spray - White	12 lbs.
2436PHDB	24x36 3/8" Anti-Spray - Black	
2436PHDW	24x36 3/8" Anti-Spray - White	14 lbs.

Poly HD Profile - Anti-Spray Back

- 3/8" Thick
- Anti-Spray Ribbed Back
- Heavy Duty



Silk-Screen Logo Rubber Mud Flaps



SILK-SCREEN LOGOS OFFER:

- Multi-Color logos with great detail!
- Long lasting urethane paint also used on floors and running tracks will **NOT WEAR OFF**
- Fast turn around



Mudflaps & Accessories



Polyguard Custom Logo Mud Flaps



Antispray Poly Mud Flaps Material Specification Sheet:

Property Material	ASTM Test Method Polyethylene	Value Polyethylene
Tensile Strength	D638	>4000 psi
Tensile Elongation	D638	>1000%
Specific Gravity	D792	0.925
Hardness, Shore D	D2240	51
Tear Resistance	D1004	>1000 psi
Flexural Modulus	D790	150,000 psi
Notched Low Temperature Brittleness	D746	-42 C



Mudflaps & Accessories

HOT STAMPED LOGOS



Raised Molded Custom Logo Mud Flaps



Standard 5/16" Rubber Raised Molded

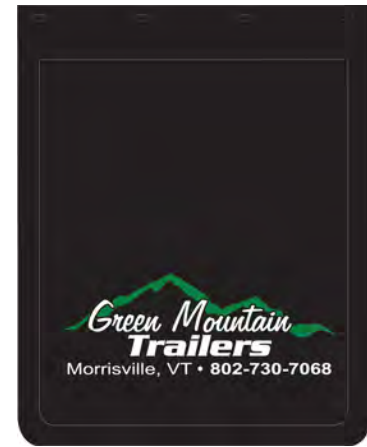

Part Number	Description	Weight Per Pair
GT-2418RSM	12" x 20" Standard 5/16" Rubber Raised Molded Custom Logo	6 lbs.
GT-2424RSM	19" x 24" Standard 5/16" Rubber Raised Molded Custom Logo	11 lbs.
GT-2430RSM	24" x 14" Standard 5/16" Rubber Raised Molded Custom Logo	11 lbs.
GT-2418RSM	24" x 18" Standard 5/16" Rubber Raised Molded Custom Logo	11 lbs.
GT-2424RSM	24" x 24" Standard 5/16" Rubber Raised Molded Custom Logo	13 lbs.
GT-2430RSM	24" x 30" Standard 5/16" Rubber Raised Molded Custom Logo	15 lbs.
GT-2436RSM	24" x 36" Standard 5/16" Rubber Raised Molded Custom Logo	17 lbs.



Heavy Duty 1/2" Rubber Raised Molded with Anti-Spray

Part Number	Description	Weight Per Pair
GT-2424HDRM	24" x 24" Heavy Duty 1/2" Rubber Raised Molded Custom Logo with Anti-Spray	19 lbs.
GT-2430HDRM	24" x 30" Heavy Duty 1/2" Rubber Raised Molded Custom Logo with Anti-Spray	22 lbs.
GT-2436HDRM	24" x 36" Heavy Duty 1/2" Rubber Raised Molded Custom Logo with Anti-Spray	24 lbs.
GT-2442HDRM	24" x 42" Heavy Duty 1/2" Rubber Raised Molded Custom Logo with Anti-Spray	26 lbs.



Raised Molded Custom Logo Mud Flaps



Rain Guard 3/8" Multi-Header Raised Molded with Anti-Spray

- Multi-Header Perfect for dump trucks, and off-road applications.
- Anti-Spray
- Anti-Sail
- Hole to Pin Flap Up to Avoid Tearing

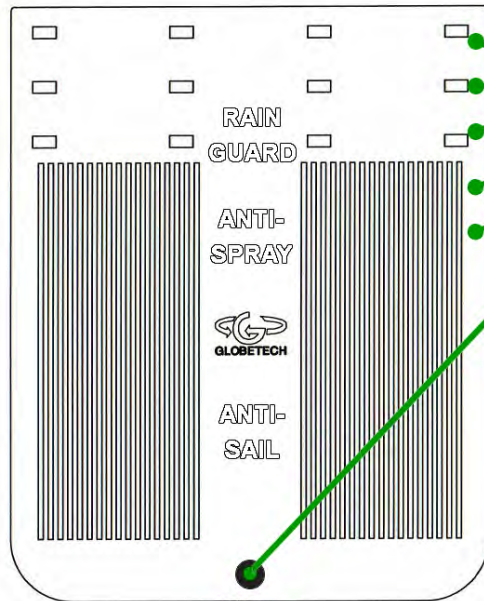

- Multi-Header
- Anti-Spray
- Anti-Sail
- Hole to Pin Flap Up to Avoid Tearing



Part Number	Description	Weight Per Pair
; H&(F; A	24" x 24" RainGuard 3/8" Rubber Raised Molded Custom Logo with Anti-Spray	14 lbs.
; H&' \$F; A	24" x 30" RainGuard 3/8" Rubber Raised Molded Custom Logo with Anti-Spray	15 lbs.
; H&' *F; A	24" x 36" RainGuard 3/8" Rubber Raised Molded Custom Logo with Anti-Spray	16 lbs.

All raised molded flaps are made in Dayton, Ohio USA.
 Our Flaps are made from 100% friction reinforced material to ensure ultimate tear strength and durability.













CUSTOM LOGO COLOR MUD FLAPS

MADE IN USA NOTE: Standard black and white available for all logo types.

Silkscreen
for rubber flaps

	Red - Pantone 185 C
	Blue - Pantone 2945 C
	Yellow - Pantone 115 C
	Green - Pantone 3298 C
	Orange - Pantone 1655 C
	Gray - P Cool Gray 5 C

Hot Stamp
for poly flaps

			
Red P 186 C	Blue P 2935 C	Dark Blue P 2965 C	Light Blue P 2925 C
			
Dark Green P 3435 C	Yellow P 116 C	Orange P 172 C	Maroon P 188 C
			Custom colors available \$100 charge per color (silkscreen & hotstamp)
Green P 348 C	Brown P 1615 C	Gray P Cool Gray 10 C	

Guidelines

RUBBER with SILKSCREEN LOGO

- Minimum order 100 each (50 pair)
- Lead time: New Logos 6-8 weeks
- Lead time: Existing logos 4-6 weeks
- Additional charge for multi-color

RUBBER with RAISED MOLDED LOGO

- Minimum order 300 each (150 pair)
- Lead time: 10-12 weeks

POLY with HOT STAMP LOGO

- Minimum order 100 each (50 pair)
- Lead time: New Logos 6-8 weeks
- Lead time: Existing logos 4-6 weeks
- Additional charge for multi-color

- Raised Molded \$300 SET-UP CHARGE 1 color only
- Additional charge for multi-color

Ordering - Call 937-274-5587 or Email PO to logos@gtmfginc.com with the following info:

- Type of flaps: Rubber or Poly
- Flap Size and Flap Thickness
- Order Quantity
- Flap Color
- Imprint (Logo) Color(s)

Artwork - Original Adobe Illustrator (vector artwork) files preferred

*we can also use high resolution .jpg, .eps, .ai, .pdf, or .png or mailed in sample flap



2700 Needmore Rd. Ph: 937.274.5587
Dayton, OH 45401 Fax: 937.274.6102

MUDFLAP PROOF

Special Notes:

Customer: _____

Attn: _____

Flap Style: _____

Print Style: Hot Stamp Silkscreen

Flap Size: _____

Imprint
Color: _____

Order Qty: _____

Set-up Fee: _____

Approved By:

Signature: _____

Printed Name: _____

Date: _____

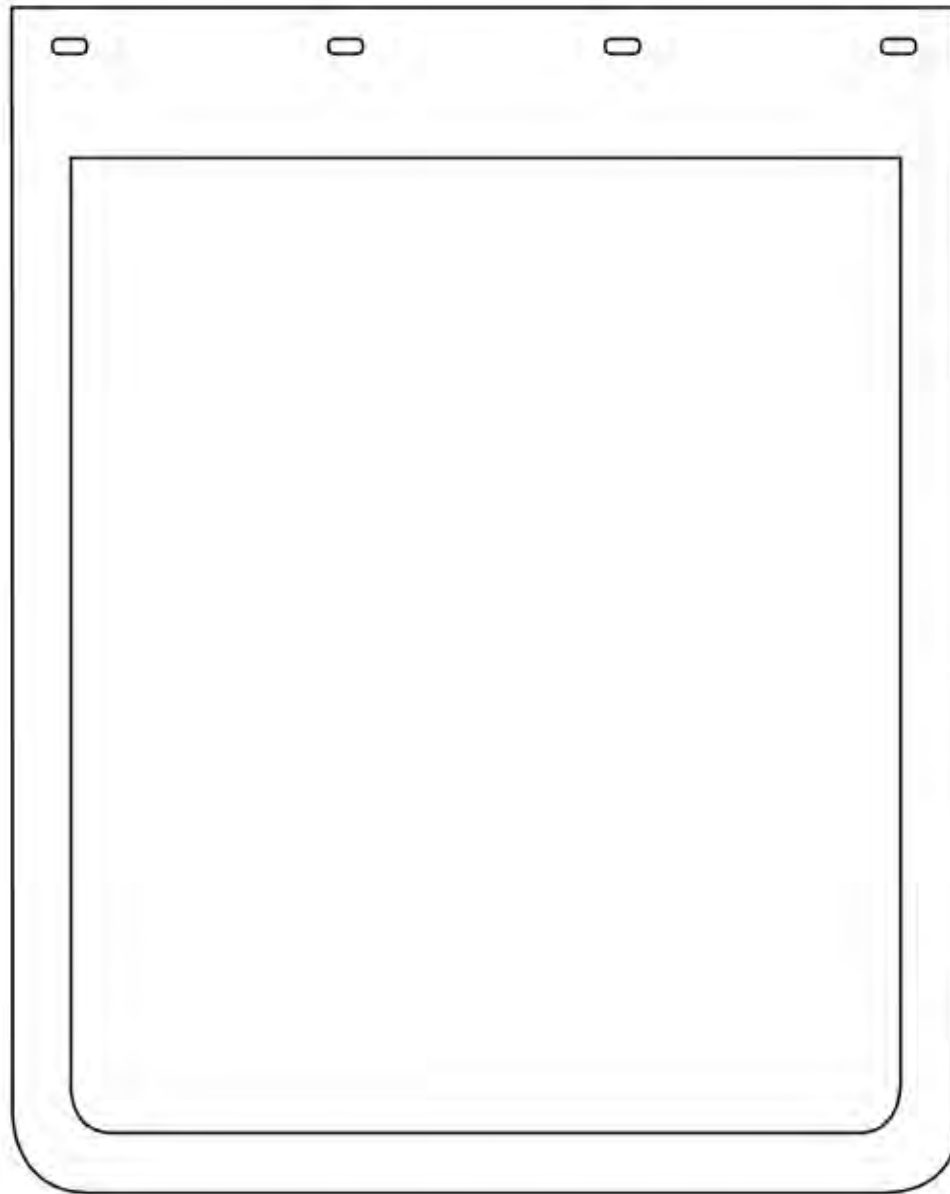

• Signed proof MUST be returned before production can begin!



Stock Raised Molded Rubber Mud Flaps



Part Number	Description
20x14WYO	20x14 Big Wonderful Wyoming Raised Molded Logo
24x30WYO	24x30 Big Wonderful Wyoming Raised Molded Logo
24x36WYO	24x36 Big Wonderful Wyoming Raised Molded Logo



Part Number	Description
12X18BIGSKY	12x18 Big Sky Montana Raised Molded Logo
20x14BIGSKY	20x14 Big Sky Montana Raised Molded Logo
24x14BIGSKY	24x14 Big Sky Montana Raised Molded Logo
24x30BIGSKY	24x30 Big Sky Montana Raised Molded Logo
24x36BIGSKY	24x36 Big Sky Montana Raised Molded Logo

Mudflaps & Accessories



Stock Logo Mud Flaps



GT-9026

GT-9021



GT-9020



GT-9014 = White Poly
GT-9015 = Black Poly
GT-9016 = Yellow Poly



GT-9017



GT-9032



GT-9019



GT-9023



GT-9024 - Black
GT-9025 - White



OHSA SPECIFIES:

1910.178(K) TRUCKS AND RAILROAD CARS

(1) The brakes of highway trucks shall be set and wheel chocks placed under the rear wheels to prevent the trucks from rolling while they are boarded with powered industrial trucks.



GT-2047D - Domestic HD Chock



- Large zinc-plated eyebolt
- Non-skid bottom
- 8"D x 10"L x 6"H

Replaces: Koneta 430030

GT-2048D - Domestic HD Chock



- Most popular design
- Zinc-plated eyebolt
- 9lbs.
- 8"D X 9-1/2"L X 5-3/4"H

GT-2049 - Contour Chock



- Molded handle on the back
- Nylon safety rope on request
- 11 pounds
- Used for heavy equipment and trucks

Replaces: Koneta 430040

GT-2050 - Standard Utility Chock



- Cored out back
- Power-coated handle
- 8 pounds
- Used by utility companies
- 8"D x 10"L x 5"H

GT-2057 - Large Chock



- 16 pounds
- 0"D x 12"L x 8"H
- Used for off-road equipment and trucks



A52475 - Chock with Chain

GT-2047D wheel chock with chain assembly can be sold separate or attached to wheel chock.



Shark Skin Trailer Bumpers

**LAST
10X LONGER**

Globetech's 4-Layer Protection

- 2-Layers of abrasion resistant, high-tear strength compound
- 2-Layers of Styrene Butadiene encapsulated nylon cord sheets
- Base rubber compound consists of fiber reinforced prime rubber containing nylon and polyester
- Resists aging from weather, ozone, heat, abrasion and chemicals.

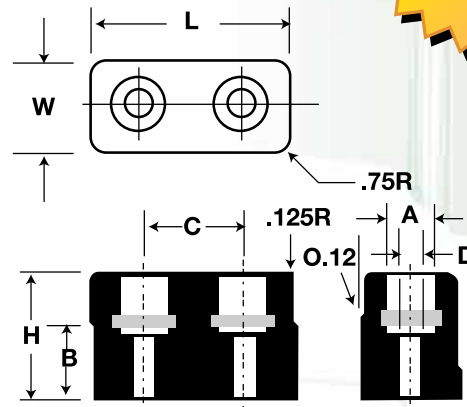

Part Number	A	B	C	D	L	W	H
GT-2000	1-1/2"	3-1/2"	3"	9/16"	6"	3"	5"
GT-2006	1-1/2"	1-3/4"	3"	9/16"	6"	3"	3-1/2"
GT-2312	1-3/8"	1-1/8"	2-5/8"	17/32"	6"	2-3/8"	3-1/4"
GT-2027	1-3/16"	1-3/4"	3-1/2"	11/16"	5-3/4"	3-3/4"	4-1/2"
GT-2042	1-1/4"	1"	4-5/8"	9/16"	7-7/8"	2-3/8"	2"
GT-2044	1-1/2"	1-1/4"	2-5/8"	17/32"	6"	2-3/4"	3"
GT-2345	1-7/16"	1-1/4"	3-1/2"	5/8"	6"	2-5/8"	3-1/4"
GT-UTM053	1-1/4"	3-1/2"	3-1/2"	17/32"	6-1/8"	3-5/8"	5-1/4"
GT-UTM172	1-1/4"	2-3/4"	3-1/2"	17/32"	6-1/8"	3-5/8"	4-1/2"
GT-UTM214	1-1/4"	1-3/4"	2-3/8"	1-7/32"	4-5/8"	2-5/8"	3-1/2"
GT-UTM259	1-1/4"	2-1/4"	3-1/2"	17/32"	6-1/8"	3-5/8"	4"
GT-UTM006	1-1/4"	1-3/4"	3-1/2"	17/32"	6-1/8"	3-5/8"	3-1/2"

Material Specifications:

- 80+5 Durometer
- Impact recovery (ASTM 1170) of 95%
- Tensile Strength 2000+ psi

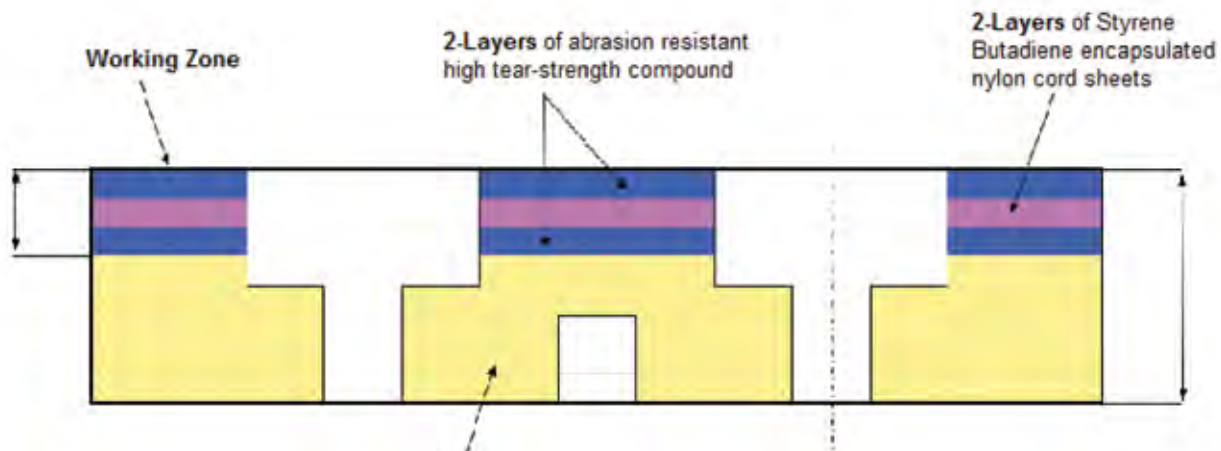



Shark Skin Trailer Bumpers



Globetech Manufacturing molded dock bumpers are the best in the industry. All bumpers are molded from fiber-reinforced rubber to ensure durability.

APPLICATIONS:

- Perfect protection for any high-traffic truck dock.
- In-plant wall protection from forklifts and other material-handling vehicles.

MATERIALS:

- Manufactured from fiber-reinforced prime rubber containing nylon and polyester.
- All bumpers have an impact recovery (ASTM 1170) of 95% with 80+ 5 durometer tensile strength.
- All molds have pre-drilled, countersunk mounting holes for easy installation and are drilled to accept 3/4" anchor bolts.

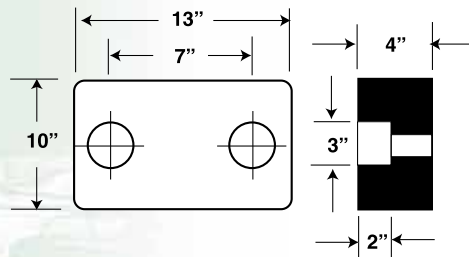

Part Number	Description	Weight
GT-2099	4" X 12" X 13"	21LBS.

Extruded Rubber Bumpers

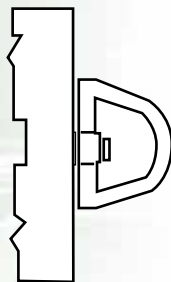

Extruded Rubber Bumpers

- Available up to 10 ft.
- For Live Stock Trailers
- Drilled holes

Part Number	Description	Weight
D-312	D-3 Dock Bumper 12" L x 3" W x 3" H	3 lbs.
D-324	D-3 Dock Bumper 24" L x 3" W x 3" H	6 lbs.
D-372	D-3 Dock Bumper 72" L x 3" W x 3" H	18 lbs.
D-412	D-4 Dock Bumper 12" L x 4" W x 4" H	6 lbs.
D-412A	D-4 Dock Bumper No Holes 24" L x 4" W x 4" H	6 lbs.
D-424	D-3 Dock Bumper 24" L x 4" W x 4" H	10lbs.
D-424A	D-4 Dock Bumper No Holes 24" L x 4" W x 4" H	10 lbs.
D-472	D-4 Dock Bumper 72" L x 4" W x 4" H	36 lbs.
D-612	D-6 Dock Bumper 12" L x 4" W x 6" H	9 lbs.
D-624	D-6 Dock Bumper 24" L x 4" W x 6" H	18lbs.
D-672	D-6 Dock Bumper 72" L x 4" W x 6" H	36lbs.

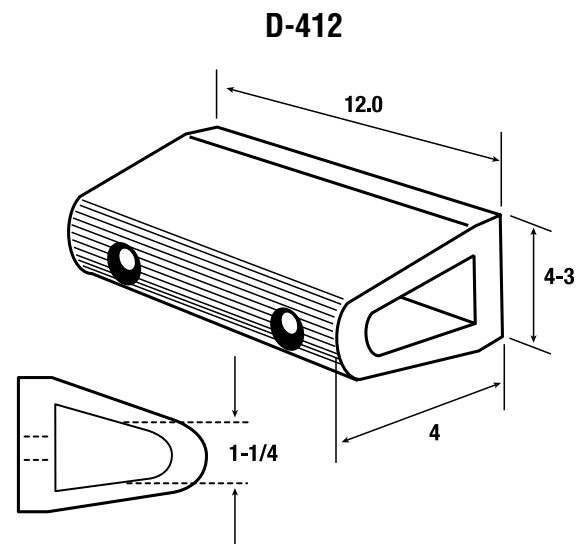

Mudflaps & Accessories



Shark Skin Trailer Bumpers



Standard Material

- Manufactured from fiber-reinforced prime rubber containing nylon & polyester
- 80+5 Durometer
- Impact recovery (ASTM 1170) of 95%
- Tensile strength = 2000+ psi
- Compression molded

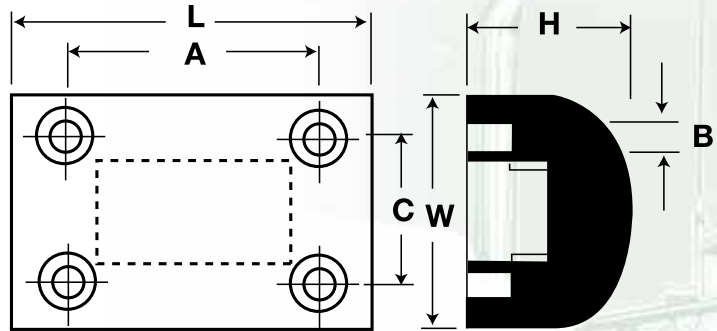

Part Number	A	B	C	L	W	H
GT-2036	5-1/2"	3/4"	3-1/4"	8"	5-1/4"	3-5/8"
GT-2045	5-1/2"	9/16"	3"	7-5/8"	5-1/2"	3-5/8"
GT-2046	5-3/8"	9/16"	3-1/8"	8"	6"	3"

Special Bumpers

Globetech can manufacture any custom molded bumper top any specification.

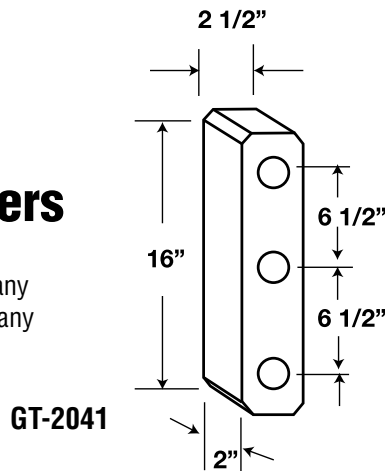

GT-2041

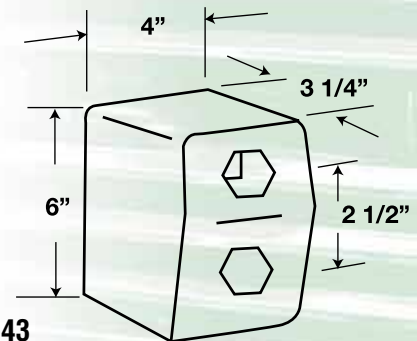

GT-2043

Part Number	Approx. Weight Each	Size
GT-2041	3lbs.	2" x 2" x 16"

Part Number	Approx. Weight Each	Size
GT-2043	3lbs.	6" x 4" x 3"



Laminated Bumpers

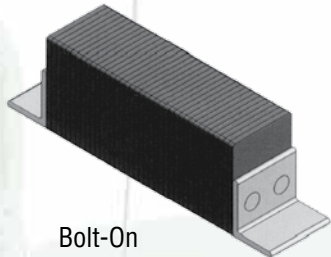

Bolt-On
GT-2100 = WAB21400170
GT-2105 = WAB21400177

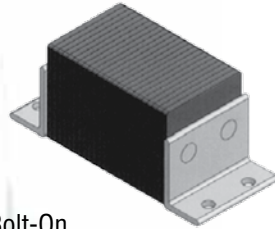

Bolt-On
GT-2101

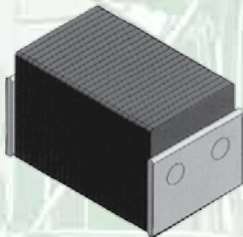

Weld-On
GT-2102

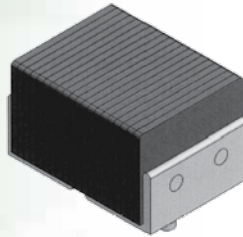

Weld-On
GT-2103

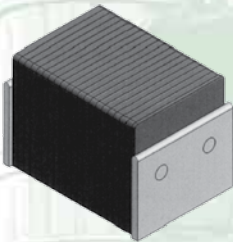

Weld-On
GT-2104

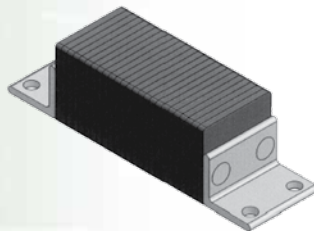

Weld-On
GT-2106

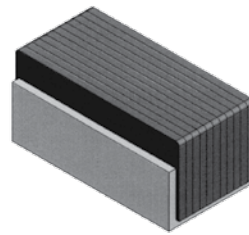

Stud Mount
GT-2107

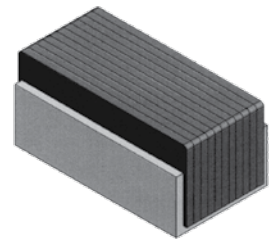

Stud Mount
GT-2109

- Stainless steel hardware
- Multi-ply belting
- Custom bumpers available

Part Number	Length	Width	Height
GT-2100	10-1/4"	3"	3-1/2"
GT-2101	6"	4"	4"
GT-2102	5-1/2"	4"	3"
GT-2103	5-1/2"	4"	3-1/4"
GT-2104	5-5/8"	4"	4"
GT-2105	9-1/2"	3"	4"
GT-2106	6-1/4"	2-7/8"	2-3/4"
GT-2107	6-1/8"	3-1/4"	2-3/4"
GT-2109	6"	2-3/4"	3"

Door Bumpers

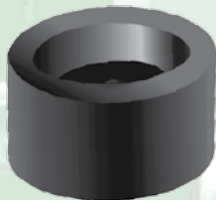

GT-025



GT-2108



GT-2613

- Made of SBR 60 Durometer

Part Number	Size	Hole Diameter
GT-025	1-7/8" x 1-5/8"	9/16"
GT-2108	1-1/2" x 3/4"	1/4"
GT-2613	2-1/2" x 1"	3/8"